Uni IT Security Notes

Notes for the IT security course at HdM Stuttgart

Felicitas Pojtinger

2022-02-01

Contents

1	Basics	5
1.1	Security Mindset	5
1.2	Aspects of IT Security	5
1.3	Security Objectives	5
1.4	Safety vs. Security	6
1.5	Attacks, Threats and Vulnerabilities	6
1.6	Risk and Threat Analysis	6
1.7	Threat Identification	6
1.8	Trade-offs in Security	7
2	Security Frameworks	7
2.1	Network Specific Threat Examples	7
2.2	STRIDE: Attacks on a Multi-User System	7
2.3	Security Policies	8
2.4	Security Mechanisms and Concepts	8
2.5	Mitigation Strategies	8
3	Malware	8
3.1	Malware General Definition	8
3.2	Infection Paths	8
3.3	Malware Types	9
3.4	Trojan Horses	9
3.5	Backdoors	9
3.6	Logic Bomb	9
3.7	Rootkit	10
3.8	Advanced Persistent Threat	10
3.9	Botnet	10
3.10	Common Reasons for Vulnerabilities	10
3.11	Side-Channel Attacks	11
3.12	Buffer Overflow	11
3.13	Race Conditions	11
4	Networking	11
4.1	TCP Overview	11
4.2	TCP Connection Establishment	12
4.3	IP Security Issues	12
4.4	TCP Security Issues	13

4.5	Port Scanning	13
4.6	TCP Protection Mechanisms	14
4.7	Session Hijacking	14
4.8	RST Attacks (In-Connection DoS)	14
4.9	Blind IP Spoofing	14
5	Perimeter Defense in Practice	15
5.1	Architecture Recommendations	15
5.2	Application in Networking	15
5.3	Stateless Packet Filter	15
5.4	Stateful Packet Filters	16
5.5	Stateful Firewalls	16
5.6	Application Layer Proxies	17
5.7	Application Level Gateways	17
5.8	Circuit Level Gateway	18
5.9	Demilitarized Zone (DMZ)	18
5.10	Web Application Firewalls (WAFs)	18
5.11	Cross-Site Scripting (XSS)	18
5.12	Cross Site Request Forgery (CSRF)	19
5.13	Intrusion Detection Systems (IDS)	19
5.14	Injections	19
6	Symmetric Encryption	20
6.1	Symmetric Encryption Overview	20
6.2	Kerckhoffs' Principle	20
6.3	Strong Algorithms	20
6.4	Crypto Attack Classes	21
6.5	Perfect Security	21
6.6	One-Time-Pad	21
6.7	Stream Cyphers	21
6.8	True Random Number Generators	21
6.9	(Cryptographically Secure) Pseudo-Random Number Generators (CSPRNG)	22
6.10	Design Principles for Block Cyphers	22
6.11	Feistel Networks	22
6.12	DES (Tripple DES)	22
6.13	AES Key Features	23
6.14	Modes of Operation for Block Cyphers	23
6.15	Cypher Block Chaining (CBC)	23

6.16 Counter Mode (CTR)	23
6.17 Padding	24
6.18 Key Length Considerations	24
7 Message Authentication	25
7.1 Message Authentication Codes (MACs)	25
7.2 General Scenario	25
7.3 Scenario with Modified Message	25
7.4 MAC Computation	26
7.5 Hash Function Requirements	26
8 Asymmetric Encryption	26
8.1 Public Key Cryptography	26
8.2 RSA Key Generation	27
8.3 RSA Encryption	27
8.4 RSA Decryption	27
8.5 RSA Security	27
8.6 Hybrid Method	28
8.7 Discrete Logarithms	29
8.8 One-Way Functions	29
8.9 Diffie-Hellman Key Exchange Protocol	29
8.10 Diffie-Hellman Key Exchange Protocol Security	30
9 Trust	30
9.1 Digital Signatures	30
9.2 RSA Signatures	31
9.3 Certificates	31
10 Transport Security	32
10.1 Internet Model	32
10.2 TLS Handshake Overview	32
10.3 TLS Record Protocol	32
10.4 Connection States	33
10.5 SSH Transport Layer Protocol	33
11 Frequently Asked Questions	34
11.1 Phishing Attacks	34
11.2 Phishing Attack Prevention	34
11.3 Certificates and CAs	35

11.4 Certificate Revocation	35
11.5 Validation of Certificates	35
11.6 Why can DES be decrypted even though F is not invertible?	35
11.7 SQL Injection	36
11.8 DNS Spoofing	36
11.9 Replay Attacks and Signatures	36
11.10VPN Access from Intranet to external Mail Server	37
11.11Stateless vs. Stateful Packet Filters/Firewalls	37
11.12Hash Functions and their Applications	37
11.13Diffie-Hellman Key Exchange Man-in-the-Middle Attack	38
11.14Diffie-Hellman Key Exchange Protocol Characteristics	38
11.15Plaintext Awareness	39
11.16Key Reuse in the One-Time Pad	39
11.17Ingress and Egress	39
11.18Caesar Cypher Vulnerability	39
11.19Authentication vs. Authorization	39
11.20TCP Vulnerabilities if PRNG is predicable	40
11.21Analog Examples for Security Objectives	40
11.22Server vs. Client Authentication in HTTPS	40
11.23Vulnerabilities of non-revoked, faked Certs	40
11.24Applied Security Objectives	40
11.25Firewall Appliance vs. Personal Firewall	41
11.26Diffie-Hellman vs. RSA	41
11.27Indirect Blocklisting	41

These study materials are heavily based on [professor Schmitz's "IT Security" lecture at HdM Stuttgart](#) and prior work of fellow students.

1 Basics

1.1 Security Mindset

- Focus on weaknesses, not on features
- Don't rely on the "good case"
- Anticipate what an attacker could do to a system
- Weight security against user experience and privacy

1.2 Aspects of IT Security

- Legal
- Technical
- Economical

1.3 Security Objectives

- **Confidentiality/conf**
 - Nobody but the legitimate receiver can read a message
 - Third party cannot gain access to communication patterns
- **Integrity/int**: The contents of communication can't be changed without the participants knowing
- **Authenticity/authN**
 - **Entity Authentication**: Communication partners can prove their respective identity to one another
 - **Message Authentication**: It can be verified that a message is authentic (unaltered and sent by the correct entity)
- **Authorization/authZ**
 - Service or information is only available to those who have correct access rights
 - Depends on authentication being set up
- **Non-Repudiation/nRep**: A sender cannot deny having sent a message or used a service

- **Availability/avail**: Service is available with sufficient performance
- **Access Control/ac**: Access to services and information is controlled
- **Privacy/priv**
 - Restricted access to identity-related data
 - Anonymity
 - Pseudonymity

1.4 Safety vs. Security

- **Safety**: Coincidental crashes or failures → On average more likely
- **Security**: Intentional attacks → Less likely

1.5 Attacks, Threats and Vulnerabilities

- **Attacker**: A person who has the skill and motivation to carry out an attack: The steps needed to carry out an attack
- **Vulnerability**: Some characteristics of the target that can result in a security breach
- **Threat**: Combination of an attacker, an attack vector and a vulnerability
- **Attack**: A threat that has been realized and has caused a security breach
- **Attack Vector**: Some characteristics of the target system that can result in a security breach

1.6 Risk and Threat Analysis

```
1 graph TD
2   subgraph Threat_analysis [Threat analysis]
3     A[System inventory and definition]-->B
4     B[Threat identification]-->C
5     C[Threat evaluation]
6   end
7
8   C-->D
9
10  subgraph Risk_analysis [Risk analysis]
11   D[Impact evaluation]-->E
12   E[Risk calculation]-->A
13 end
```

1.7 Threat Identification

- Define **system boundaries**: What is part of your system, what is not?

- Define **security objectives**: What is important for your system to be secure?
- **List all threats** you can think of: Brainstorming and discussion with experts
- Use **conventions**:
 - Similar threat models
 - Requirement specifications
 - How to break or circumvent the specifications
 - Note security assumptions of the system
 - Be careful with perimeter security: What if perimeter has been breached?
 - Note *possible*, but not yet exploitable vulnerabilities

1.8 Trade-offs in Security

- **Costs increase exponentially** with increased security
- **User friendliness decreases linearly** with increased security
- Risk analysis can be used when tuning the level of security

2 Security Frameworks

2.1 Network Specific Threat Examples

- Remote Attacks
- Eavesdropping: Sniffing of information
- Altering information
- Spoofing
- DoS
- Session hijacking
- Viruses attacking clients
- Spam
- Phishing
- Data trails/privacy leaks

2.2 STRIDE: Attacks on a Multi-User System

- **S**poofing of Identity
- **T**ampering with Information
- **R**epudiation

- Information Disclosure
- DoS
- Escalation of Privileges

2.3 Security Policies

- Classification of system states into “allowed” and “forbidden” states
- Secure system: Is only in allowed states
- Breached system: Is in forbidden state

2.4 Security Mechanisms and Concepts

```
1 graph TD
2   A[Security policy]-->|requires|B
3   B[Security objectives]-->|realized by|C
4   C[Security mechanisms]-->|described by|D
5   D[Security concept]
```

2.5 Mitigation Strategies

- **Reduce:** Increase effort for attacker
- **Assign:** Decrease damage for target
- **Accept:** Accept remaining risk

3 Malware

3.1 Malware General Definition

- Performs unwanted functions
- Often runs without user’s consent
- Telemetry (often hidden in proprietary software behind EULAs)
- Backdoors

3.2 Infection Paths

- **Direct infection:** Mail → Executable

- **Exploitation of vulnerabilities:** Over network, drive-by infection (downloads which a person has authorized but without understanding the consequences)
- **External devices:** USB sticks
- **Bundled** with other functionality: Trojan horses

3.3 Malware Types

- **Computer viruses**
 - **Boot sector** virus (infects all drives)
 - **File** virus
 - **Macro** virus
 - **Worm:** Network based virus
- Trojan horses; adware
- Key loggers, spyware
- Botnet software
- Ransomware: Extortion

3.4 Trojan Horses

- Has server and client parts
- Server is used for installation, which the client then confirms
- Once installed, an attacker can take control
 - Reading sensitive data
 - Key logging
 - Botnet integration

3.5 Backdoors

Intentionally created remote code execution vulnerability/ingress into system (*Hello, Five Eyes!*).

3.6 Logic Bomb

Malicious function, which is called once condition evaluates to true.

3.7 Rootkit

Collection of services installed on a compromised system, which enables hiding ...

- Logins
- Processes
- Files

from users other than `root`.

3.8 Advanced Persistent Threat

Advanced:

- Attack is customized to target host (one node)
- High effort
- Targets are i.e. VIPs or institutions

Persistent:

- First infected host is used to infiltrate the entire system
- Scans for login information to create an account for the attackers

Threats: Often uses Zero-Day vulnerabilities

3.9 Botnet

- Infected host does work for somebody external
- Master controls the bots and distributes updates to stay hidden
- Dynamic: Needs to handle hosts being turned on/off and has to hide its existence
- Can be used to send spam, DDoS attacks, hosting of malicious sites

3.10 Common Reasons for Vulnerabilities

Issues in ...

- Architecture
- Design
- Implementation

... lead to attack vectors:

- **Client side:** Browser, office software, E-Mail, media players, ...
- **Server side:** Web apps, OS services, Anti-virus/backup software
- **Relaxed security policies:** User has too many capabilities
- **Abuse of protocols:** Instant messaging can be used as remote control, BitTorrent for distribution etc.
- **Zero-day attacks:** Non-public vulnerabilities

3.11 Side-Channel Attacks

Indirect (physical) attack on a system; i.e. smudge patterns on a smartphone

3.12 Buffer Overflow

- Application provides finite buffer for input but does not check size of input
 - Buffer can overflow
 - Overwriting internal information or allowing attacker to insert machine code to jump back into
 - Possible due to Von Neumann architecture: Programs in data are stored in the same memory
 - C does not check bounds (`gets`, `strcpy`, `memcpy`, `printf` etc.)

3.13 Race Conditions

Information is being changed after it has been checked, but before it has been executed.

4 Networking

4.1 TCP Overview

- Characteristics
 - Reliable
 - Connection-Oriented
 - Full-Duplex
 - Layer atop IP
 - Connection management: Setup, Release and Abort

- Ordered delivery (package sequence control)
- Repetition of lost packets
- End-to-End ACKs
- Checksum in header
- Identified by a 5-tuple
 - Source IP
 - Destination IP
 - Transport Protocol
 - Source Port
 - Destination Port

4.2 TCP Connection Establishment

- Virtual connection between two systems
- 3-Way-Handshake with connection states

An example connection from the client to the server:

1	<Client>					<Server>
2						
3	[Closed]					[Closed]
4		SEQ=x	CTL=SYN		=>	
5	[SYN Sent]					
6		<=	SEQ=y	CTL=SYN+ACK	ACK=x+1	
7						[SYN Received]
8		SEQ=x+1	CTL=ACK		ACK=y+1 =>	
9	[Established]					[Established]

4.3 IP Security Issues

- IP header doesn't have confidentiality or integrity protection
 - Faking the sender address is easy to do
 - Traffic can be analyzed by sniffing packet headers
- IP payload doesn't have confidentiality or integrity protection
 - Eavesdropping is possible by sniffing packets
- Loose coupling with lower layers:
 - Easy to divert traffic

- Availability can be easily attacked
- Confidentiality and integrity can't be guaranteed
- Unprotected error signaling via ICMP: Fake error messages can affect availability
- DNS is insecure; i.e. DNS spoofing

4.4 TCP Security Issues

- TCP header doesn't have confidentiality or integrity protection
- **Session hijacking**
 - When sniffing session details, attacker can impersonate a peer in a TCP connection
 - Attackers can guess session details and attack remotely using spoofed IP addresses
- **RST attack**: Attackers can reset/abort attacks by injecting packets with the RST flag
- **Port scanning**
 - Find out open ports
 - Determine software running on port
- **SYN flooding**
 - Overload system resources by initializing many connections and not pursuing them

4.5 Port Scanning

- Objective: **Collect information** about ...
 - Installed services
 - Software versions
 - OS
 - Firewall
- Enumeration based on port
 - Well-known ports (i.e. SSH → 22)
 - Invalid connection requests: Different way of error handling can be used to fingerprint the OS
- Possible scanning methods
 - **TCP connect** scan
 - **Half-open** scan
 - **SYN-ACK** scan
 - **ACK** scan

4.6 TCP Protection Mechanisms

- SYN flood protection
 - Limit rate of SYN packets
 - SYN cookies (RFC 4987)
 - * Limit resources
 - * Half-open connections are not stored in the connection table but instead as a hash in the ISN
 - * Only if the 3rd ACK handshake packet matches the sequence number, the connection is added to the connection table
 - * Server does not need to maintain any state information on half-open connections: Resources can't be exhausted
- Connections are only accepted if the sequence numbers are within a certain range of acceptable values (attackers would have to sniff sequence numbers or guess them)

4.7 Session Hijacking

- Attacker takes over existing connection between two peers
- Requirement: Attacker has to sniff or guess sequence numbers of the connection correctly

4.8 RST Attacks (In-Connection DoS)

Inject packet with RST flag into ongoing connection: Connection has to be aborted immediately

4.9 Blind IP Spoofing

Firewall is configured to only allow one source IP address and destination IP address (A → B).

To circumvent this restriction:

1. Attacker starts DoS attack on A to prevent A from sending RST packets to B
2. Attacker sends TCP connection setup packet with A's source IP address to B
3. B sends SYN+ACK packet to A, but can't respond due to DoS
4. Attacker sends TCP connection ACK packet to B with ACK matching the initial sequence number chosen by B (which has to be guessed, as B sent the SYN+ACK packet to A, not the attacker)

Only works if B uses a predictable algorithm for its ISN and packet filters aren't in place.

5 Perimeter Defense in Practice

5.1 Architecture Recommendations

- Known from medieval cities, castles etc.
- Definition of system boundary between “inside” and “outside”
- Different threat models for inside and outside
 - **Inside:** Trusted
 - **Outside:** Untrusted
- Objectives
 - Create said boundary
 - Only a defined set of communication relations is allowed
 - Special security checks
 - Limited number of interconnection points
 - Simpler to manage and audit than a completely open architecture
- Problems
 - Requires intelligent selection of system boundaries
 - May require multiple levels of perimeters
 - No system/user in the “trusted inside” can truly be trusted

5.2 Application in Networking

- Installing security devices at the network border
- Separation of network areas into inside/outside
- Prevent sensitive information from being sent to the outside (view the system in the inside as the potential, probably unintentional attacker)
- Multiple levels can increase security
- But: Perimeter security is not sufficient on its own!
 - There will probably be additional non-secured paths into the network (i.e. `ssh -R`)
 - Some malicious traffic might look like “normal” traffic and can pass

5.3 Stateless Packet Filter

- Access Control List (ACL): Applies set of rules to each incoming packets
- Discards (denies, blocks) or forwards (allows, permits) packets based on ACL

- Typically configured by IP and TCP/UDP header fields
- Stateless inspection: Established connections can only be detected with the ACK control flag
- Can be easy to misconfigure by forgetting essential protocols
 - DNS
 - ICMP
- Advantages
 - Fast/High throughput
 - Simple to realize
 - Software-based, can be added as a package
 - Simple to configure
- Disadvantages
 - Inflexible
 - Many attacks can only be detected using stateful filtering
 - Rules and their priorities can easily get confusing
- Default discard policy
 - Block everything which is not explicitly allowed (allowlist)
 - Issue: The security policy has to be revised for each new protocol or service
 - This rule must come last/have the lowest priority, behind all “allowing” rules

5.4 Stateful Packet Filters

- Store connection states
- Can make decisions based on
 - TCP connections
 - UDP replies to previous outgoing packet with same IP:Port relation (“UDP Connection”)
 - Application protocol states
- Similar to application layer gates/proxy firewalls, but less intruding in communication
- Rules can be more specific than in stateless packet filters
- Rules are easier to enforce, i.e. incoming TCP packets don’t have to be allowed in because they have ACK set

5.5 Stateful Firewalls

- Tries to fix the problems of stateless inspection

- To many packets have to be allowed by default (ACK → No SYN-scanning protection)
- Protocols like FTP or SIP, which dynamically allocate port numbers, can't be filtered securely
- Create state per TCP or UDP flow
 - Source and Destination IP:Port
 - Protocol
 - Connection state
- A packet which is not associated with a state is dropped immediately
- Packets which belong to a previously established TCP/UDP "connection" are allowed to pass without further checks
- State tables have to be cleaned up periodically to prevent resource starvation

5.6 Application Layer Proxies

- Protected host during connection establishment
- Different kinds
 - Application level
 - Circuit level
 - Forward proxy (client-side)
 - Reverse proxy (server-side)

5.7 Application Level Gateways

- Conversion between different application layer protocols
- Evaluation up to OSI layer 7
 - Protocol verification
 - Authentication
 - Malware scanning
 - Spam filtering
 - Attack pattern filtering
- Advantage: Security policies can be enforced at application level
- Disadvantage: Computing and memory performance requirements

5.8 Circuit Level Gateway

- Checks/controls at TCP connection level
- Creates separate connection to outside and inside
- Checks data before it is being sent to the transport layer

5.9 Demilitarized Zone (DMZ)

- **Outside world:** Global Internet
- **Outside router:** Routes packet to and from bastion host
- **Bastion host:** Proxy server and relay host
- **Inside router:** Routes packets only to and from bastion host
- **Inside (protected):** Intranet

The DMZ creates 2/3 lines of defense by the use of a stub network.

Multi-Level DMZs can create even more secure perimeter defenses:

Global Internet → Access Router and Packet Filter → Public Services Host (offers i.e. public Web services) → Screening Router and Packet filter (prevents IP spoofing) → Mail host (for external mail communication) → Bastion host (i.e. proxy for FTP and Web access) → Intranet

5.10 Web Application Firewalls (WAFs)

- Acts on the application layer
- Is a reverse proxy
- Can protect the web server from “evil” client input
 - Cross-Site scripting
 - SQL injection: Filters out JS or SQL commands in client input by removing special symbols (i.e. <, ' etc)
 - Cookie poisoning: Stores the hash values of sent cookies
 - HTML manipulation: Encrypts URL parameters

5.11 Cross-Site Scripting (XSS)

Injection of malicious client-side code (JS, WASM) into site. There are multiple types:

- **Reflected/non-persistent XSS:** Attacker provides malicious data i.e. via URL → server adds malicious code to page → browser executes the malicious code

- **DOM-based XSS:** Attacker provides malicious data i.e. via URL → client (app running in the browser) adds malicious code to page → browser then executes the malicious code
- **Stored (persistent) XSS:** Attacker provides malicious data using i.e. their profile page, *POSTs* it to the server → server stores it i.e. in a database → Client then requests i.e. the attacker's profile page → server loads the malicious data from the database → adds the stored malicious code to the page → browser then executes the malicious code

5.12 Cross Site Request Forgery (CSRF)

Sniffing of cookies/tokens from a connection in another tab.

5.13 Intrusion Detection Systems (IDS)

- Security product that is specialized on detecting anomalies during live operation of networks and computers
 - Virus/Botnet activity
 - Suspicious network activity (malware phoning home)
- Basic Approaches
 - **Signature based:** Use attack signatures/known malicious communication activity patterns
 - **Anomaly based:** Significant deviation from previously recorded baseline activity
 - **Rule based:** Define allowed by behavior by app-specific set of legitimate actions
- Actions
 - Send out alarm
 - Logging
 - Blocking of known patterns
- Realization
 - Appliance
 - Integration in firewall
 - Integration into host

5.14 Injections

- **SQL injection:** SQL commands are sent to the database because neither server nor client escape i.e. '

- **HTML injection:** Parameters in HTML forms can also be sent using a [POST](#) request

6 Symmetric Encryption

6.1 Symmetric Encryption Overview

Alice:

1. Creates message
2. Chooses key
3. Computes ciphertext
4. Send ciphertext to Bob

Eve (Attacker):

1. Copies ciphertext
2. Tries to guess the key

Bob:

1. Receives ciphertext
2. Uses key
3. Computes plaintext
4. Reads message

6.2 Kerckhoffs' Principle

- From “La Cryptographie Militaire”
- Most important point: **The security of a crypto system must lie in the non-disclosure of the key but not in the non-disclosure of the algorithm**
- Implementation
 - Keep secret which function you used for encryption
 - But a disclosure of the set of functions should not create a problem

6.3 Strong Algorithms

- There is **no attack that can break it with less effort than a brute force attack** (“complete enumeration”)
- There are so many keys that a **complete search of key space is infeasible**

6.4 Crypto Attack Classes

- **Active** attacks
 - Most relevant for cryptographic protocols
 - Active interference (modification, insertion or deletion of messages)
 - Man in the middle (MITM) can receive messages and modify them on the way to the receiver
- **Passive** attacks: Pure eavesdropping, without interference with communication

6.5 Perfect Security

Ciphertext does not give any information you don't already have about the plaintext ($p(m(c)) = p(m)$)

6.6 One-Time-Pad

- **Vernam Cypher**: Create ciphertext by XOR addition of secret key and plaintext
- **Mauborgne**: Random key, never re-use key ("one time")
- **Shannon**: OTP is unbreakable if key is ...
 - Truly random
 - As large
 - Never reused
 - Kept secret

6.7 Stream Cyphers

Encryption like one-time-pad, but using pseudo-random bits instead of true random (using a **Cryptographically Secure Pseudo-Random Number Generator (CSPRNG)**)

6.8 True Random Number Generators

- Output can't be reproduced or predicted
- Is based on physical processes

6.9 (Cryptographically Secure) Pseudo-Random Number Generators (CSPRNG)

PSRNGs compute the output based on a seed and an internal state.

A CSPRNG must ...

- Be unpredictable
- Be computationally infeasible to compute the next outputs

... when the initial state of the CSPRNG is not known

6.10 Design Principles for Block Cyphers

Two methods for frustrating a statistical analysis:

- **Confusion:** The ciphertext should depend on the plaintext in such a complicated way that an attacker cannot gain any information from the ciphertext (redundancy should not be visible anymore in the ciphertext)
- **Diffusion:** Each plaintext and key bit should influence as many ciphertext bits as possible
 - Changing one bit in plaintext → Many pseudo-random changes in ciphertext
 - Changing one bit in the key → Many pseudo-random changes in ciphertext

6.11 Feistel Networks

- Described by Horst Feistel
- Algorithm
 - Plaintext block B is divided in 2 halves
 - Derive r round key keys from key
 - Feed one half through round function F
 - Then XOR the result with the other half
 - Exchange halves
- Repeat r times

6.12 DES (Tripple DES)

- Single DES breakable in less than 24h (complete search of key space)
- Tripple DES is still secure
- Three steps of DES on each data block using up to three keys

- Decryption in reverse sequence
- 3 independent keys are the most secure
- Three same keys can be used for (insecure) DES compatibility

6.13 AES Key Features

- FIPS standard 197
- Key length: 128/192/256 bit
- Block size: 128 bit
- Iterative rounds of substitutions and permutation, but no Feistel structure
- 10, 12 or 14 rounds
- Blocks of 16 bytes arranged in 4x4 state matrix
- Components of the round function are invertible and independent of key
 - **Substitute Bytes:** Non-linear substitution of bytes in state
 - **Shift Rows:** Cyclic shifting of rows
 - **Min Columns:** Multiplication of state elements with a fixed 4x4 matrix M

6.14 Modes of Operation for Block Cyphers

- Objective: Encrypt multiple plaintext blocks with the same block cypher
- Straightforward solution: blockwise encryption (“Electronic Codebook Mode”)
- Problem: Patterns in the distribution of plaintext blocks remain visible

6.15 Cypher Block Chaining (CBC)

- Avoids telltale patterns in ciphertext
- Decryption fails if a data block is missing or corrupted
- Each data block is encrypted in relation to the previous block

6.16 Counter Mode (CTR)

- Simple and efficient
- Random access still possible
- No issues if data block is missing
- Incrementing counter is involved in randomization per data block

6.17 Padding

- Plaintext needs to be a full number of blocks
- If plaintext does not fill the last block completely, it must be padded before encryption
 - In order to facilitate safe decryption, the last block is always padded: For example for a block size of n bytes, there are $1 \dots n$ bytes added to the plaintext before encryption
 - Decryption can check last bytes and strip them off correspondingly
- Always need to pad with at least one byte!
- Common methods
 - Pad with bytes of the same value as the number of padding bytes (PKCS#5; i.e. if there are three bytes to be padded, add $0x03 \ 0x03 \ 0x03$)
 - Pad with $0x80$ followed by $0x00$ bytes
 - Pad with zeroes except for the last byte that indicates the number of padding bytes
 - Pad with zeroes
 - Pad with space characters ($0x20$)

6.18 Key Length Considerations

- Cryptography is always a matter of complexity
 - With enough time and/or space, all schemes can theoretically be broken
 - “brute force” attacks
 - Example: 56bit keys DES can be broken in <24h since 1999
- Meanwhile
 - 128bit keys have to be replaced in the coming years
 - 192bit keys are secure in medium term
 - 256bit keys are hard to crack due to physical boundaries (“state of the art”)
- Quantum computers might be able to crack keys much more quickly
- Numbers refer to unbroken algorithms in symmetric cryptography
 - Broken algorithm is one where an n bit key can be determined trying out significantly less than 2^n keys

7 Message Authentication

7.1 Message Authentication Codes (MACs)

- Objectives
 - **Integrity protection:** Prevent unauthorized manipulation of data
 - **Message authentication:** Prevent unauthorized origination on behalf of others
- Idea: Compute a cryptographic checksum (MAC)
- Required Properties
 - Cannot be counterfeited; without having the sender's secret, it is too complex to ...
 - * Find another message matching the same MAC
 - * Construct a suitable MAC for another message
 - Even smallest changes to message cause a big change of the MAC

7.2 General Scenario

Alice:

1. $m = \text{"I love you. Alice"}$
2. Select secret key K
3. Compute $MAC_K(m)$

Bob:

1. Receives m'
2. Selects secret key K
3. Computes $MAC_K(m')$
4. Compares computed MAC with received MAC → Matches!

Assertion: If computed MAC equals the MAC included in the received message, an owner of the key (Alice) really sent this message and it was not changed on the way.

7.3 Scenario with Modified Message

Alice: Same as in [General Scenario](#)

Mallory:

- $m = \text{"It's all over! Alice."}$

Bob

1. Receives m'
2. Selects secret key K
3. Computes $MAC_K(m')$
4. Compares computed MAC with received MAC → Doesn't match!
5. Ignore m

7.4 MAC Computation

- Requirements
 - Shared key k between sender and receiver
 - Hash function to create a code that changes if the message has been altered
- Using **block cypher** f_k and **hash function** $hash$: $MAC(m) = f_k(hash(m))$
- Using a **key dependent cryptographic hash function** $hash(k, m)$: $MAC(m) = hash(k, m)$

7.5 Hash Function Requirements

- Weak **collision resistance**: For a given message and hash it is impossible/to complex to find another message such that the hashes match
- **One-way** property
 - Easy to compute hash
 - Impossible to find message from hash

8 Asymmetric Encryption**8.1 Public Key Cryptography****Alice:**

1. Generates key pair (PK_{Alice}, SK_{Alice})
2. Published PK_{Alice} at Trent's
3. c received → decrypts $m = D_{SK_{Alice}}(C)$

Trent:

- Stores public keys

- Provides public keys on request

Bob:

1. Wants to send m to Alice confidentially
2. Obtains PK_{Alice} from Trent
3. Computes $c = E_{PK_{Alice}}(m)$
4. Sends c to Alice

8.2 RSA Key Generation

Also see the [handwritten notes](#).

1. Alice chooses 2 large prime numbers p, q and computes $n = p \cdot q, \phi(n) = (p - 1)(q - 1)$
2. Alice chooses an integer e with $1 < e < \phi(n)$ that is relatively prime to $\phi(n)$
3. Alice computes an integer d with $1 < d < \phi(n)$ and $d \cdot e = k \cdot \phi(n) + 1$
4. Alice publishes her public key $PK_{Alice} = (e, n)$
5. Alice keeps her private key $SK_{Alice} = d$ and $p, q, \phi(n)$ secret

8.3 RSA Encryption

Also see the [handwritten notes](#).

1. Bob obtains $PK_{Alice} = (e, n)$
2. Bob composes plaintext $m \in M = \{1, 2, \dots, n - 1\}$
3. Bob computes the ciphertext $c = E_{PK_{Alice}}(m) = m^e \pmod n$
4. Bob sends c to Alice

8.4 RSA Decryption

Also see the [handwritten notes](#).

Alice can obtain the plaintext message m by computing $m = D_{SK_{Alice}}(c) = c^d \pmod n = m^{ed} \pmod n$

8.5 RSA Security

- **RSA problem:** Given e, n and $c = m^e \pmod n$, find m

- Most efficient approach to solve the RSA problem is currently the integer factorization of n : An upper limit to the complexity of the problem; can be used to derive the private key from the prime factors
- Quantum computers will be more efficient in doing integer factorization (Shor's algorithm)
- RSA problem and integer factorization still lack mathematical proof for their complexity

- **Organizational properties**

- **Authenticity** of the public key (e, n)
- **Confidentiality** of the secret key (d, p, q)

- **Mathematical properties**

- **Complexity of factoring** the modulus n
- **Complexity of solving** the RSA problem

- Failure of any properties will compromise the security of the method!

8.6 Hybrid Method

Combination of asymmetric and symmetric key methods.

Alice:

1. Generates key pair (PK_{Alice}, SK_{Alice})
2. Publishes PK_{Alice} at Trent's
3. c received \rightarrow Decrypts $K = D_{SK_{Alice}}(c)$
4. Alice and bob switch over to the symmetric key algorithm with key K

Trent:

- Stores public keys
- Provides public keys on request

Bob:

1. Obtains PK_{Alice} from Trent
2. Generates symmetric key K
3. Computes $c = E_{PK_{Alice}}(K)$
4. Sends c to Alice

8.7 Discrete Logarithms

Primitive element: Let p be a prime number. An element $g \leq p - 1$ is called primitive element mod p if for each $A \in \{1, 2, \dots, p - 1\}$ there is an x such that $A = g^x \pmod{p}$

Discrete logarithm: Let p be a prime number and let $g \leq p - 1$ be a primitive element mod p . Then an element x is called discrete logarithm of A to base $g \pmod{p}$ if $A = g^x \pmod{p}$.

Discrete logarithm problem: Given A, g, p , find $x \leq p - 1$ with $A = g^x \pmod{p}$

8.8 One-Way Functions

- “Trap-door” functions
- Easy to compute in one direction (i.e. $f(x) = g^x \pmod{p}$)
- Hard to invert
 - Ideally only possible using complete enumeration of all possible inputs
 - I.e. for a given y you need to try out all possible values $x = 0, 1, \dots, p - 1$ to find one $x_0 : f(x_0) = y$
- Definition of complexity often of the P and NP complexity classes
 - **P:** Answer of a problem can be found in polynomial time (b bits of problem size \rightarrow algorithm takes time b^k)
 - **NP:** Answer of problem cannot be found in polynomial time (b bits of problem size \rightarrow algorithm takes time k^b), but the correctness of given answer can be checked in polynomial time

8.9 Diffie-Hellman Key Exchange Protocol

Purpose: Allow communication partners without prior knowledge of another to establish a shared secret key over an insecure communication channel

Also see the [handwritten notes](#).

1. Alice and Bob agree publicly on prime number p and a primitive element $g \leq p - 1$
2. Alice randomly chooses $\alpha \in \{2, \dots, p - 2\}$ and computes $A = g^\alpha \pmod{p}$
3. Bob randomly chooses $\beta \in \{2, \dots, p - 2\}$ and computes $B = g^\beta \pmod{p}$
4. Alice and Bob publicly exchange A and B
5. Alice and Bob hold a common secret key K :
 1. $K_B = A^\beta \pmod{p} = g^{\alpha\beta} \pmod{p}$
 2. $K_A = B^\alpha \pmod{p} = g^{\alpha\beta} \pmod{p} = K_B$

8.10 Diffie-Hellman Key Exchange Protocol Security

It depends on three properties which can't be relaxed:

- **Discrete logarithm problem:** There is no efficient inversion for integer exponentiation
- **Authenticity** of exchanged messages: No protection against MITM attacks!
- **Diffie-Hellman problem complexity:** Given $g, p, A = g^x \pmod p, B = g^y \pmod p$ find $K = g^{xy} \pmod p$

9 Trust

9.1 Digital Signatures

- Requirements
 - **Tamper-proof**
 - **Unambiguous attribution** of signature to signing person/identity
 - **Inseparable connection** between signature and signed document
 - **Non-repudiability** of signature
- Typical approach
 - Encrypt hash of document with secret key
 - Signature can be verified using the public key

Alice:

1. Generates key pair (PK_{Alice}, SK_{Alice})
2. Publishes PK_{Alice} at Trent's
3. Computes $sig_{Alice}(m) = E_{SK_{Alice}}(hash(m))$

Trent:

- Stores public keys
- Provides public keys on request

Bob:

1. Obtains PK_{Alice} from Trent
2. Computes $hash(m_{received})$
3. Decrypts signature $D_{PK_{Alice}}(sig_{received})$
4. Compares $hash(m_{received})$ to the received signed hash

9.2 RSA Signatures

- Conventions
 - $PK_{Alice} = (e, n)$
 - $SK_{Alice} = d$
 - m is the message to be signed
 - h is the secure hash function
- **Computation** of signature: $sig_{Alice}(m) = (h(m))^d \bmod n$
- **Verification** of signature
 - Bob receives (m', sig')
 - Bob computes $h(m')$ and $(sig')^e \bmod n$
 - If both match, the signature is verified

9.3 Certificates

- A certificate (cert) certifies that a certain public key belongs to a certain identity (“person”)
- Certificates are digitally signed by service providers (Certificate Authorities, CAs) or government agencies (i.e. COVID certs)
- **X.509**: ITU standard for a common certificate format; contains
 - Version (v3)
 - Serial number (unique within the CA)
 - Signature algorithm
 - Issuer name (name of the CA)
 - Time of validity (not before, not after)
 - Subject name (who the cert is for)
 - Subject public key info (public key of subject, algorithm of public key)
 - ID of signature algorithm
 - Certificate signature algorithm
 - Certificate signature value (signature of the CA which signs the cert)
- Certificates never contain secrets (i.e. private keys)

10 Transport Security

10.1 Internet Model

- 7: Application Layer: HTTP, SMTP, ...
- Between: TLS, SSH, ...
- 4: Transport Layer: TCP, UDP, ...
- 3: Internetwork Layer: IP
- 2: Data Link Layer: IEEE 802.x
- 1: Physical Layer: IEEE 802.x
- (0): Physical transmission medium: Wire, fiber, wireless

10.2 TLS Handshake Overview

```
1 title TLS Handshake
2
3 Client->Server: Hello
4 Server->Client: Hello
5 Server->Client: Cert public key
6 Server->Client: Hello Done
7
8 note over Client: Pre-master secret
9 note over Client: Symmetric key
10
11 Client->Server: Change cypher key exchange
12 Client->Server: Client finished
13
14 note over Server: Pre-master secret
15 note over Server: Symmetric key
16
17 Server->Client: Change cypher sec
18 Server->Client: Finished
19
20 Client<->Server: Encrypted data transfer
```

10.3 TLS Record Protocol

Sender:

1. Fragmentation
2. Compression (optional)
3. MAC computation (Key dependent; MD5, SHA-1, SHA-256 etc.)

4. Encryption

Receiver:

1. Decryption
2. MAC verification
3. Decompression (optional)
4. Reassembly

10.4 Connection States

- Each side has four connection states
 - One for each direction (read/write)
 - One current and one pending set of states
 - * Parameters negotiated by the TLS handshake protocol
 - * Pending states made current by the change cypher spec protocol
- Security parameters
 - Connection end (client/server)
 - Bulk encryption algorithm
 - MAC algorithm
 - Compression algorithm
 - Master secret
 - Client random
 - Server random
- Security items for both directions (client write/server write)
 - Encryption keys
 - MAC secrets
 - Initialization vectors (in case of block cypher)
 - Sequence numbers (no wrapping)

10.5 SSH Transport Layer Protocol

- Tasks
 - Server authentication
 - Negotiation of algorithms and keys

- Confidentiality and integrity protection (for application data)
- Prerequisites
 - Server has a public key (“host key”)
 - Client has a trustworthy copy of the host key
 - Reliable transport protocol (TCP) between client and server

11 Frequently Asked Questions

11.1 Phishing Attacks

- Attacker tries to get a user to log in with a fake mail and a fake site
- Attacker steals the login information of the user in order to get access to bank accounts or credit card info
- Many options in addition to mail
 - Malware (Keylogger)
 - DNS-based phishing (Redirection to fake site)
 - Man-in-the-middle Phishing
 - XSS
- Violated security objectives
 - **Authenticity:** Attacker pretends to be a different company
 - **Confidentiality:** Non-secured connection
 - **Authorization:** The attacker can steal credentials
 - **Privacy:** The attacker can get identity-related info by access to the user’s account
 - **Non-repudiation:** The attacker can transfer money

11.2 Phishing Attack Prevention

- Spam filters: Most phishing mails can be filtered using a spam filter
- A link’s text should be compared to the actual URL (the `href` tag)
- Check the URL in the address bar
- Antivirus-Apps
- Using an up-to-date system
- Checking the certificates of a site
- Using HTTPS

11.3 Certificates and CAs

- Certifies properties of people or objects and their authenticity and integrity using cryptographic processes
- A public key certificate provides the public key of a person or organization and confirms it
- Certificates are signed by the service provider/certificate authority (CA) or a government authority (i.e. COVID-19), which adds to trust

11.4 Certificate Revocation

- As soon as a cert's private key has been leaked, it needs to be revoked by putting it on a certificate revocation list
- Before a cert should be used it should be checked if it has not been revoked yet
- There are also other reasons for cert revocation
 - Change of certificate metadata (i.e. name change)
 - Dissolution of the organization
 - Removal of privileges

11.5 Validation of Certificates

- Certificate has the service provider's/CA's signature
- The signature is a hash of the certificate encrypted with the CA's private key, which can be validated by decrypting it with the CA's known public key
- Date validity needs to be checked
- Revocation needs to be checked
- Risks
 - Revocation checks are crucial because they allow a user to verify the identity of the owner of the site and discover whether the certificate authority still considers the digital certificate trustworthy
 - Attacker could fake a site using a revoked certificate

11.6 Why can DES be decrypted even though F is not invertible?

- DES uses a Feistel Network
- Key is divided and only one half is put through the round function
- Both halves are joined using XOR

- In order to decrypt a block, the same algorithm is used, but the divided keys are used in the opposite order

11.7 SQL Injection

- Inputs from forms, API requests etc. are passed to the database without any validation for embedded snippets
- Embedded SQL snippets will run on the DB, allowing the attacker to run any snippet on the database
- Violated security objectives
 - **Authorization:** Access is granted without authorization
 - **Confidentiality:** Access to info in database
 - **Integrity:** Data can be manipulated
 - **Privacy:** Access to potentially identity-related private info
 - **Availability:** Database could be dropped, which would take the system down (no schema after attack)

11.8 DNS Spoofing

- Attacker sends fake DNS answers and pretends to be the relevant nameserver
- Attacker needs to send the fake answer before the relevant nameserver can; this is for example possible by a DoS attack
- Attacker can also add a fake entry to `/etc/hosts`
- Violated security objectives
 - **Authenticity:** Attacker pretends to be someone else
 - **Confidentiality:** Attacker eavesdrops on communication with DNS server

11.9 Replay Attacks and Signatures

- Attacker tries to communicate using a packet which they sniffed beforehand
- Can be provided by using a random number or nonce, which is also being encrypted; the number would have to be guessed
- Encryption and signatures don't help prevent replay attacks as decryption is not required to replay the attack
- Violated security objectives
 - **Authenticity:** Attacker can pretend to be someone else

- **Authorization:** If sniffed packet contains login info

11.10 VPN Access from Intranet to external Mail Server

- VPN gateway is required
- IPSec tunnel mode can be used
- Firewall rules, VPN connection and routing tables need to be configured

11.11 Stateless vs. Stateful Packet Filters/Firewalls

- **Stateless:** Decides what to do with packets based on static values
 - IP:Port of source/destination
 - TCP flags
- **Stateful:** Decides what to do using a state table
 - Keeps track of connections using a state table (new/established/related/...)
 - Can detect MTU changes and packet fragmentation
 - Can't secure application layer from viruses
 - Decides what to do with packets based on dynamic values
 - * TCP connections
 - * UDP replies to previous outgoing packet with same IP:Port relation ("UDP connection")
 - * Application protocol states
 - Drops unsolicited requests: Packets which don't match known criteria or are part of a DoS attack

11.12 Hash Functions and their Applications

- Cryptographic hash functions are a special type of hash function which is collision resistant and a one-way function
- Maps a string of any length to a string of fixed length
- Is injective but not necessarily surjective
- Applications
 - Data processing
 - Integrity checks of data or messages
 - Obfuscation of passwords (/etc/shadow)

- Data base of digital signatures
- PRNGs: Pseudo-random number generators
- Construction of block cyphers
- Used in i.e. SHA256, MD5, ...

11.13 Diffie-Hellman Key Exchange Man-in-the-Middle Attack

- The key exchange is vulnerable to a MITM attack
- Mallory intercepts Alice's public value and sends her own public value to Bob
- When Bob transmits his public value, Mallory substitutes it with her own and sends it to Alice
- Mallory can now decrypt any messages sent out by Alice or Bob, read, modify and re-encrypt them with the appropriate key and send them
- This attack is possible because the key exchange does not authenticate the participants
- Authentication can be done using digital signatures or other protocol variants

11.14 Diffie-Hellman Key Exchange Protocol Characteristics

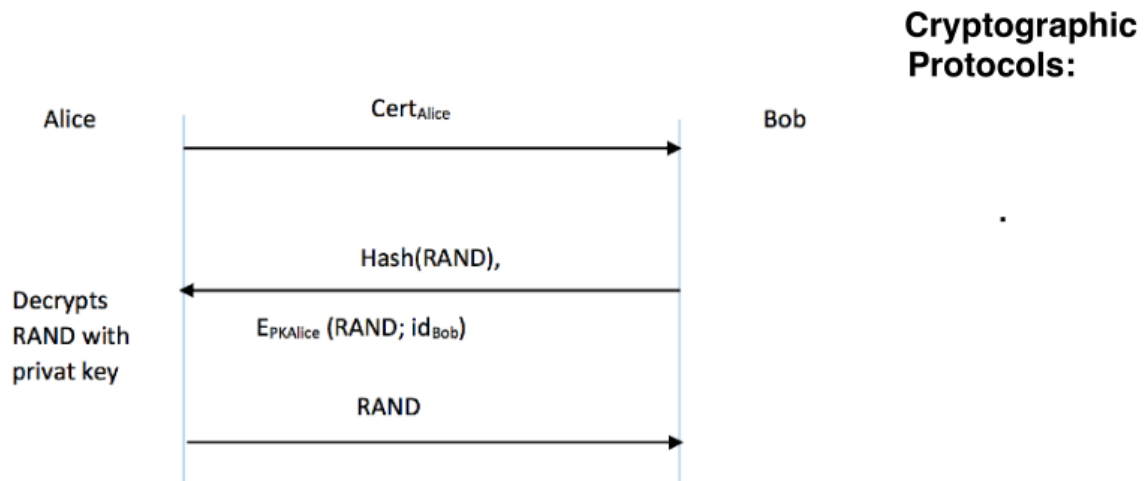

Figure 1: Sequence diagram of protocol

It is an asymmetric challenge-response protocol which is used to provide authentication by checking authentication factors. It does so by sending a hash of a random number, which has been encrypted using Alice's public key/cert, to Alice, who then decrypts the hash and sends it to Bob.

11.15 Plaintext Awareness

- It is hard, even with an efficient algorithm, to create a valid ciphertext if plaintext is not taken into account
- If an attacker tries to send a message to Bob using ciphertext and Alice accepts it as valid, it is not plaintext aware
- In the [example above](#), Alice has more ways to check its validity however (hash etc.), which would not be the case if it were a symmetric response-challenge protocol
- Known Plaintext Attack
 - Attacker sniffs the challenge and the response
 - Tries to use cryptographic methods to get the used password
 - Worked in GSM systems

11.16 Key Reuse in the One-Time Pad

The following is no longer true (C = Cypher, K = Key, M = Message):

$$C1 = M1 + K \quad C2 = M2 + K \quad D = C1 - C2 = (M1 + K) - (M2 + K) = M1 - M2$$

The difference D now has the same characteristics like $M1 - M2$; this means that frequency analysis can be used.

11.17 Ingress and Egress

- **Ingress Filtering:** Incoming packets are not allowed to have IP from internal address range to protect against spoofing
- **Egress Filtering:** Packets leaving internal networks have to have a source IP from internal range to protect against spoofing and to prevent packets from the internal network from leaking to outer network

11.18 Caesar Cypher Vulnerability

- Key range is way too small (26)
- Frequency analysis can be used (i.e. checking for e)

11.19 Authentication vs. Authorization

- **Authentication:** Communication partners can proof their identity to one another

- **Authorization:** Access is only available to those with specific permission

11.20 TCP Vulnerabilities if PRNG is predictable

Attacker can generate a sequence number, which can be used in an existing session between two communication partners → Enables session hijacking

11.21 Analog Examples for Security Objectives

- **Authenticity:** Checking the student ID card
- **Integrity:** Writing with a ball pen instead of a pencil
- **Availability:** Storing an additional copy of the exam questions at the examination office

11.22 Server vs. Client Authentication in HTTPS

A web server is typically accessible to anyone; it is not important who accesses it. A client however wants to know that a site is trustworthy/authentic, which is why typically only the server is authenticated.

11.23 Vulnerabilities of non-revoked, faked Certs

- Anyone can impersonate who the cert has been given too
- To prevent this, the certs need to be added to a CRL

11.24 Applied Security Objectives

A person is communicating with amazon.com.

- Validating that they are actually communicating with amazon.com: amazon.com needs a certificate, which is to be checked by the client → **Authentication**
- Making sure that credit card info can't be eavesdropped on: Needs encryption, i.e. HTTPS → **Confidentiality, Privacy**
- Ensuring that nobody can buy something using their information: Needs to be behind i.e. a Password, i.e. HTTPS with HTTP digest authentication → **Authorization**
- Validating that a mail to many employees has actually been sent by the CEO: Digital signature, combined with a certificate to verify the signature → **Authenticity, Integrity, Non-Repudiation**
- Air traffic control can't be offline: DoS protection and failovers → **Availability**

11.25 Firewall Appliance vs. Personal Firewall

- Appliance: Can't filter by application
- Personal: Can't protect against OS vulnerabilities and is easily misconfigured

11.26 Diffie-Hellman vs. RSA

- Diffie-Hellman allows creating a shared secret key for symmetric encryption over an insecure communication channel
- RSA uses public and private keys for asymmetric encryption; only public keys need to be exchanged

11.27 Indirect Blocklisting

Sender's mail address is faked and used to send spam, which leads the recipient to block the sender's address, despite them never having sent any spam themselves. Can be fixed by checking signature and certificate instead and blocking based on signature or blocking all messages without signature or certificate.